

DESIGN FILE No.	12999		7/8" FLANGE - HARD SOLDER
CHECKED	K.J.T.		
WEIGHT			
SHEET No.	SHEET 1 OF 1		
ISSUE	08	DIMENSIONS IN MILLIMETRES	35.20000

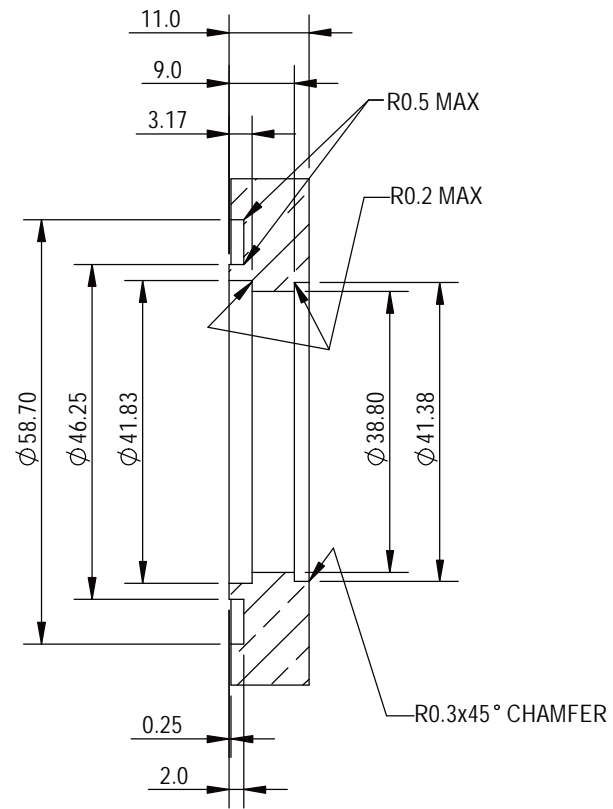

SECTION A-A

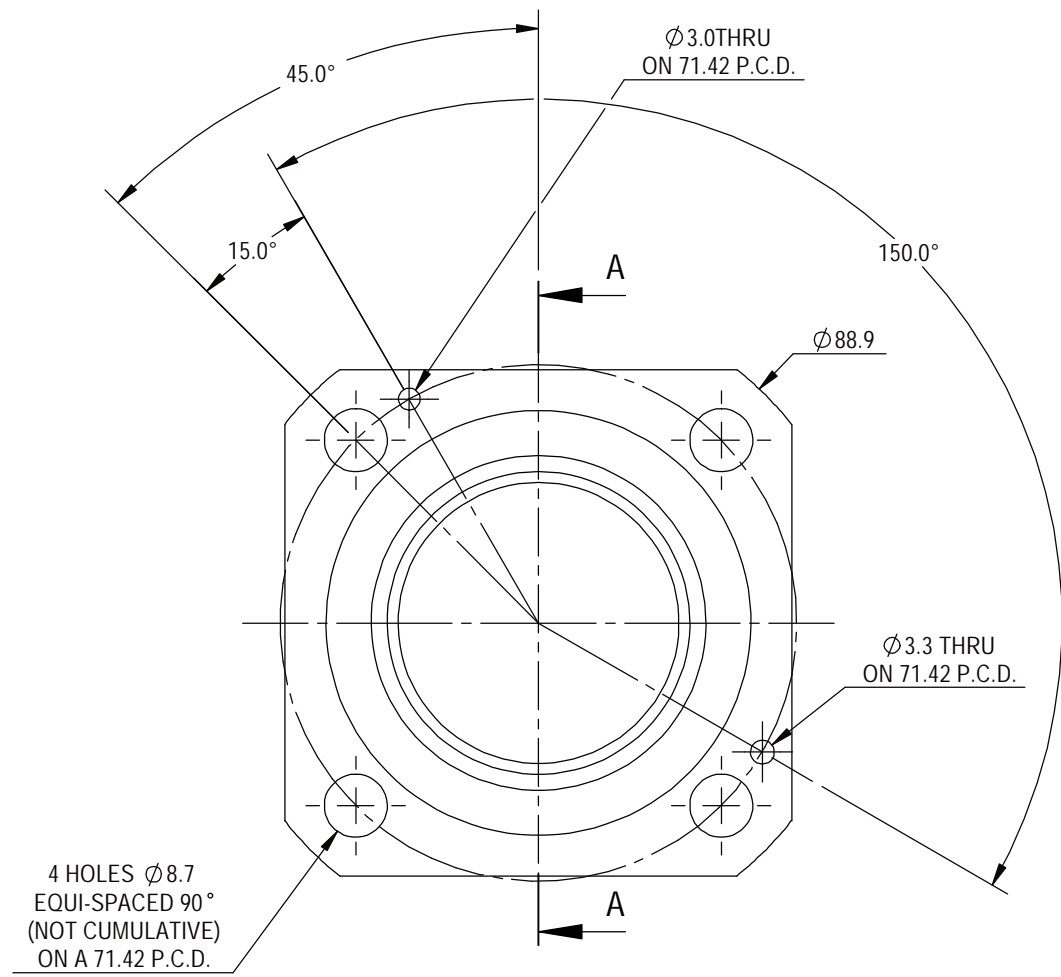
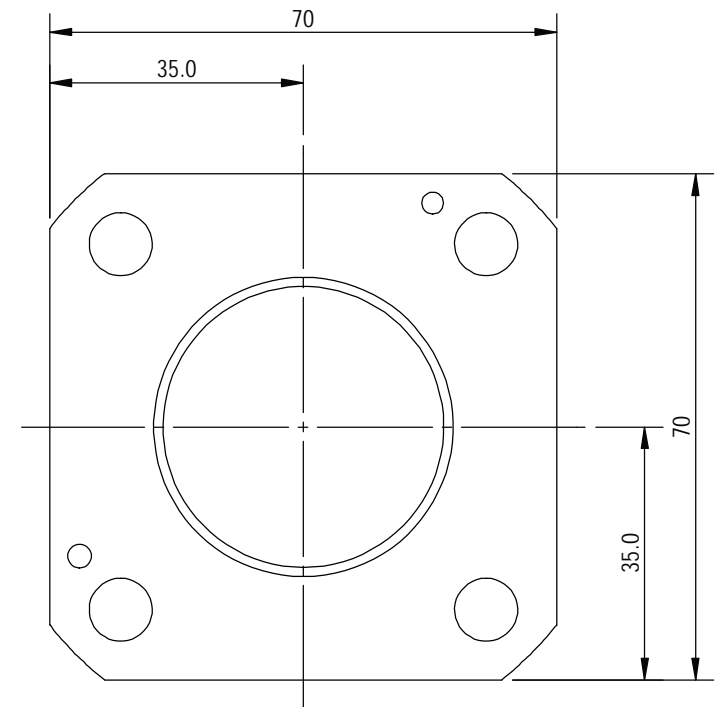

DESIGN FILE No.	ECM15244
CHECKED	K.J.T.
WEIGHT	
SHEET No.	SHEET 1 OF 1
ISSUE	07



DIMENSIONS IN MILLIMETRES

1-5/8 FLANGE-HARD SOLDER

36.20004

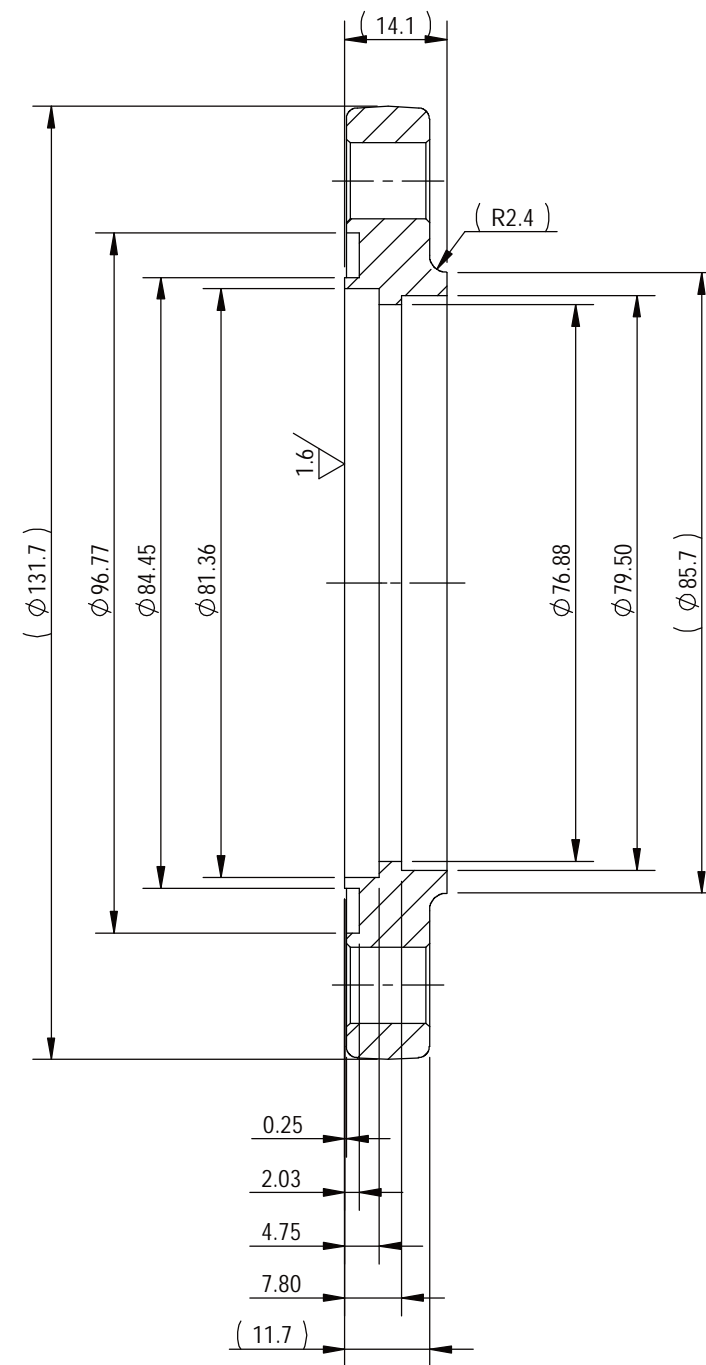
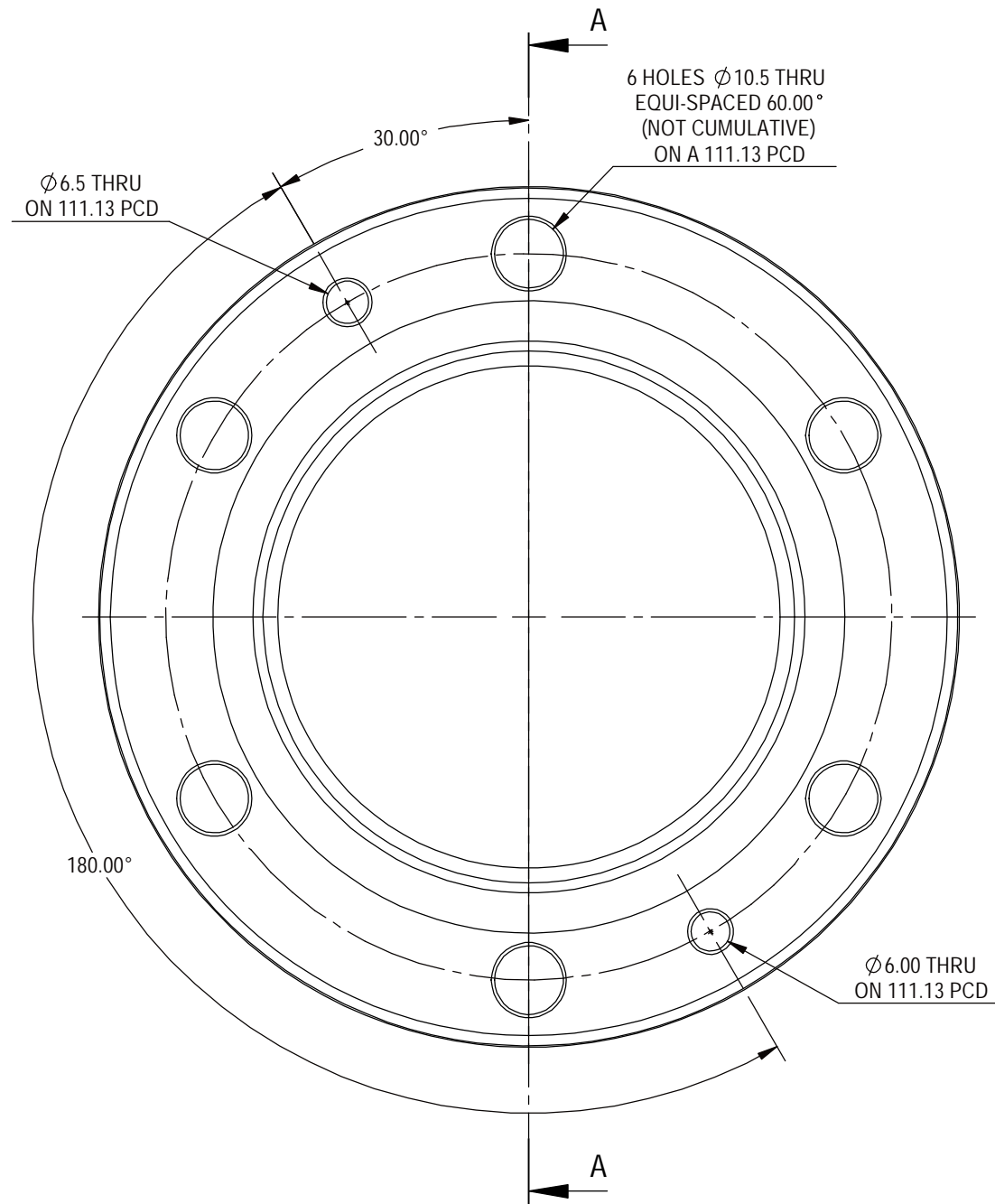

SECTION A-A

DESIGN FILE No.	ECM15682		3-1/8 FLANGE-HARD SOLDER  37.20008
CHECKED	K.J.T.		
WEIGHT			
SHEET No.	SHEET 1 OF 1		
ISSUE	06	DIMENSIONS IN MILLIMETRES	

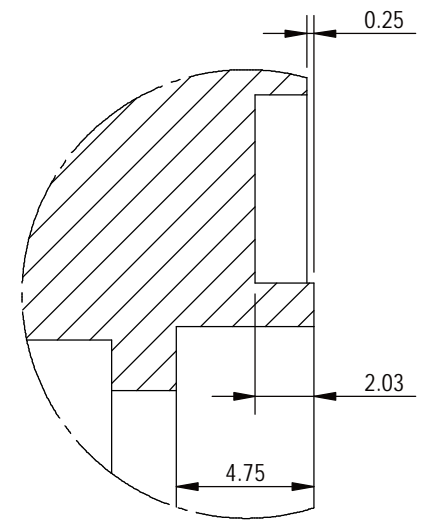
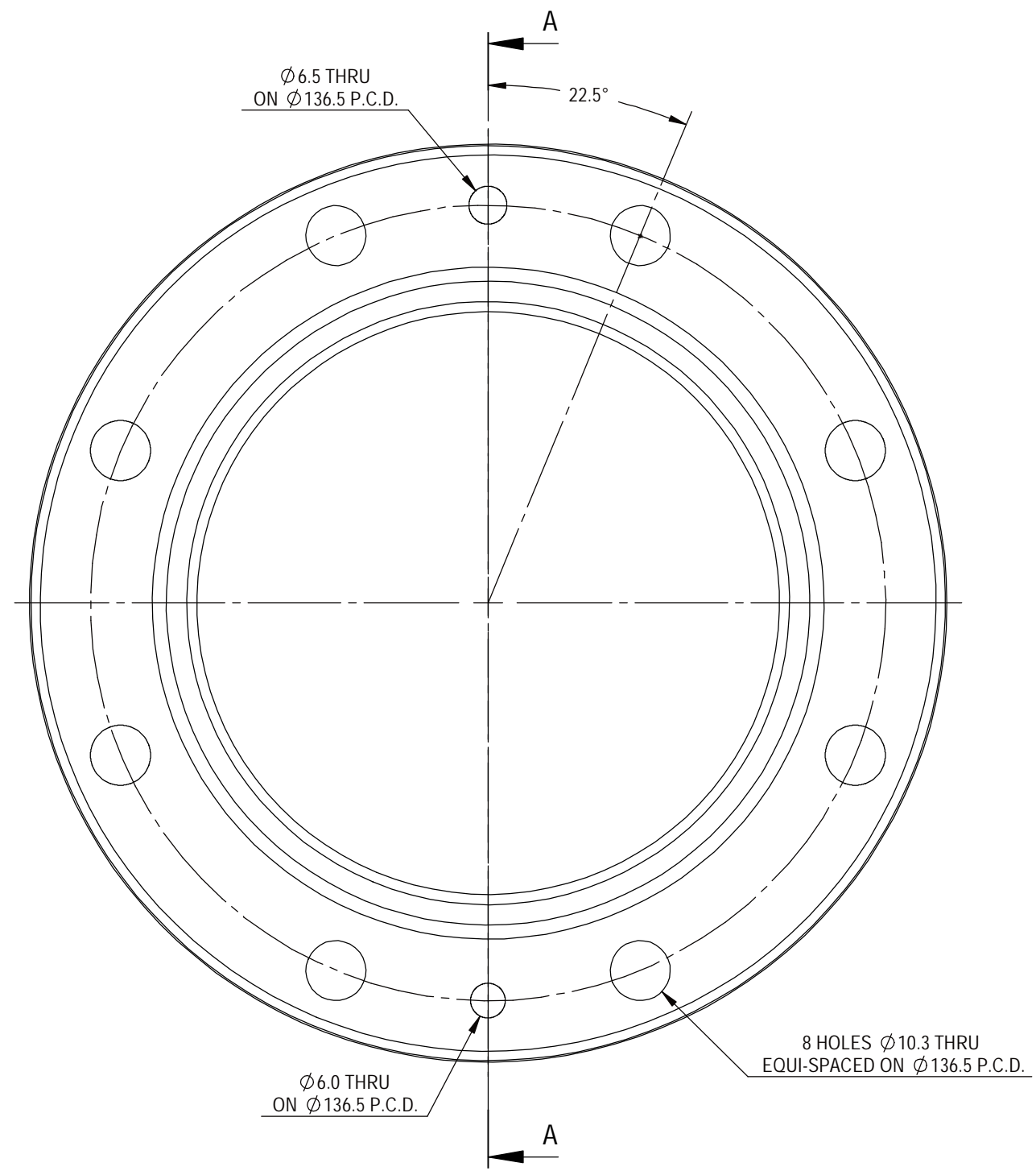

DETAIL B  
SCALE 4:1

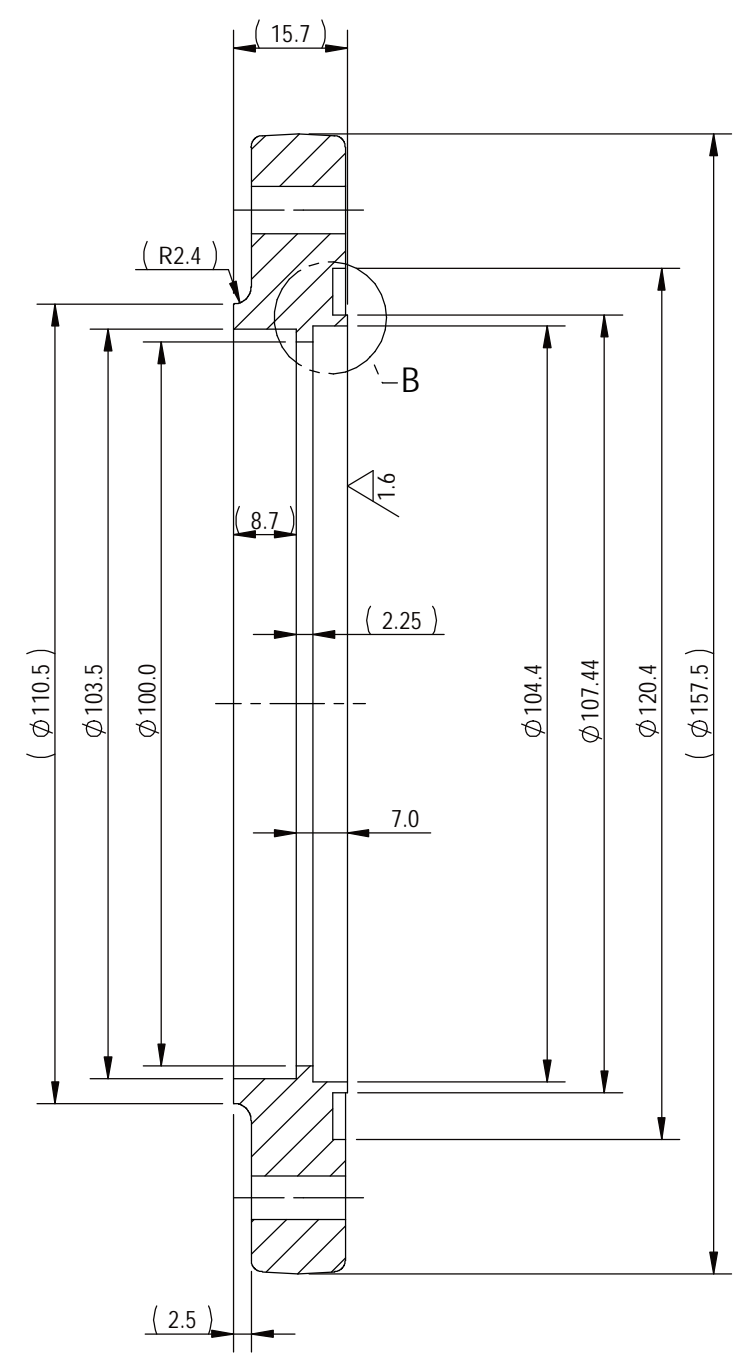

SECTION A-A

DESIGN FILE No.	ECM15457
CHECKED	K.J.T.
WEIGHT	
SHEET No.	SHEET 1 OF 1
ISSUE	04

**RFS** RADIO  
FREQUENCY  
SYSTEMS

DIMENSIONS IN MILLIMETRES

FLANGE - HARD SOLDER 406

50.20011

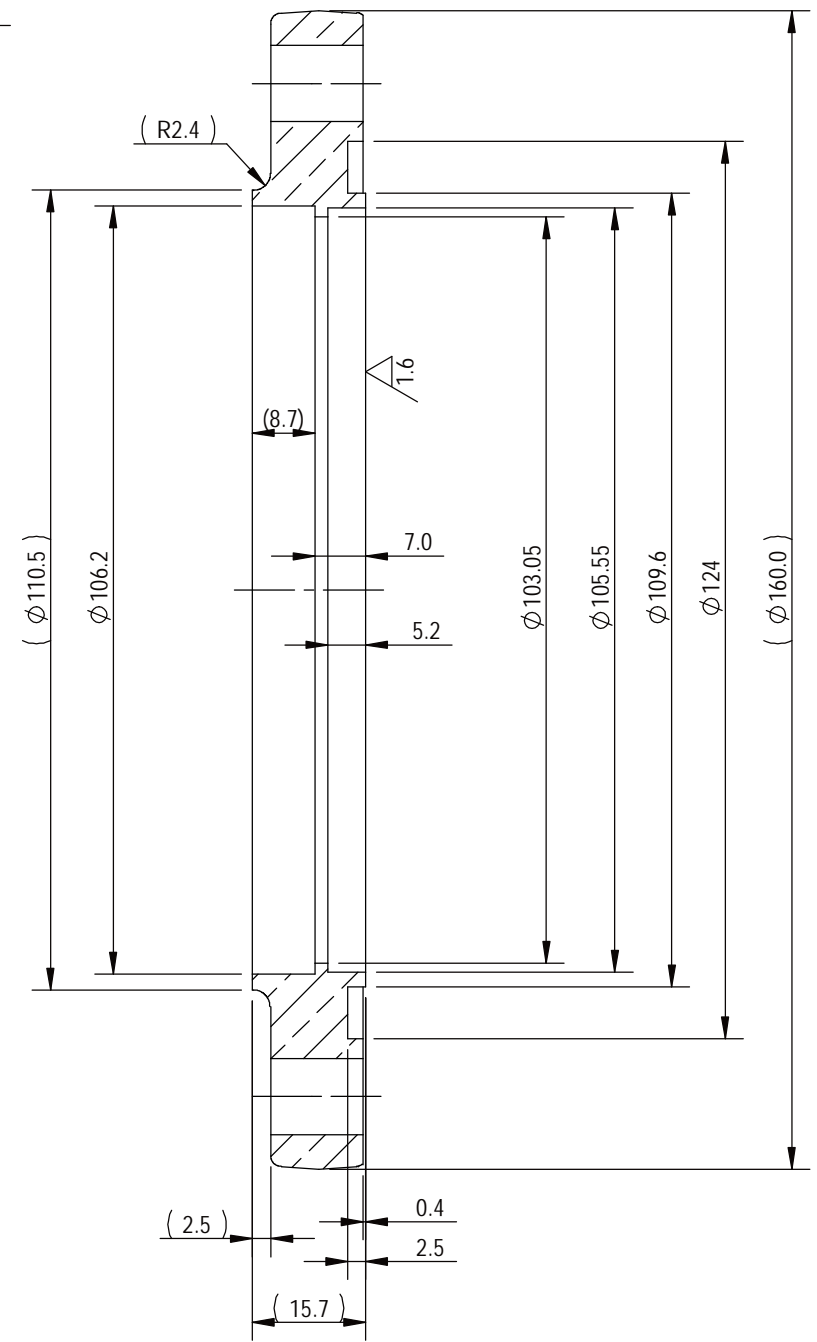
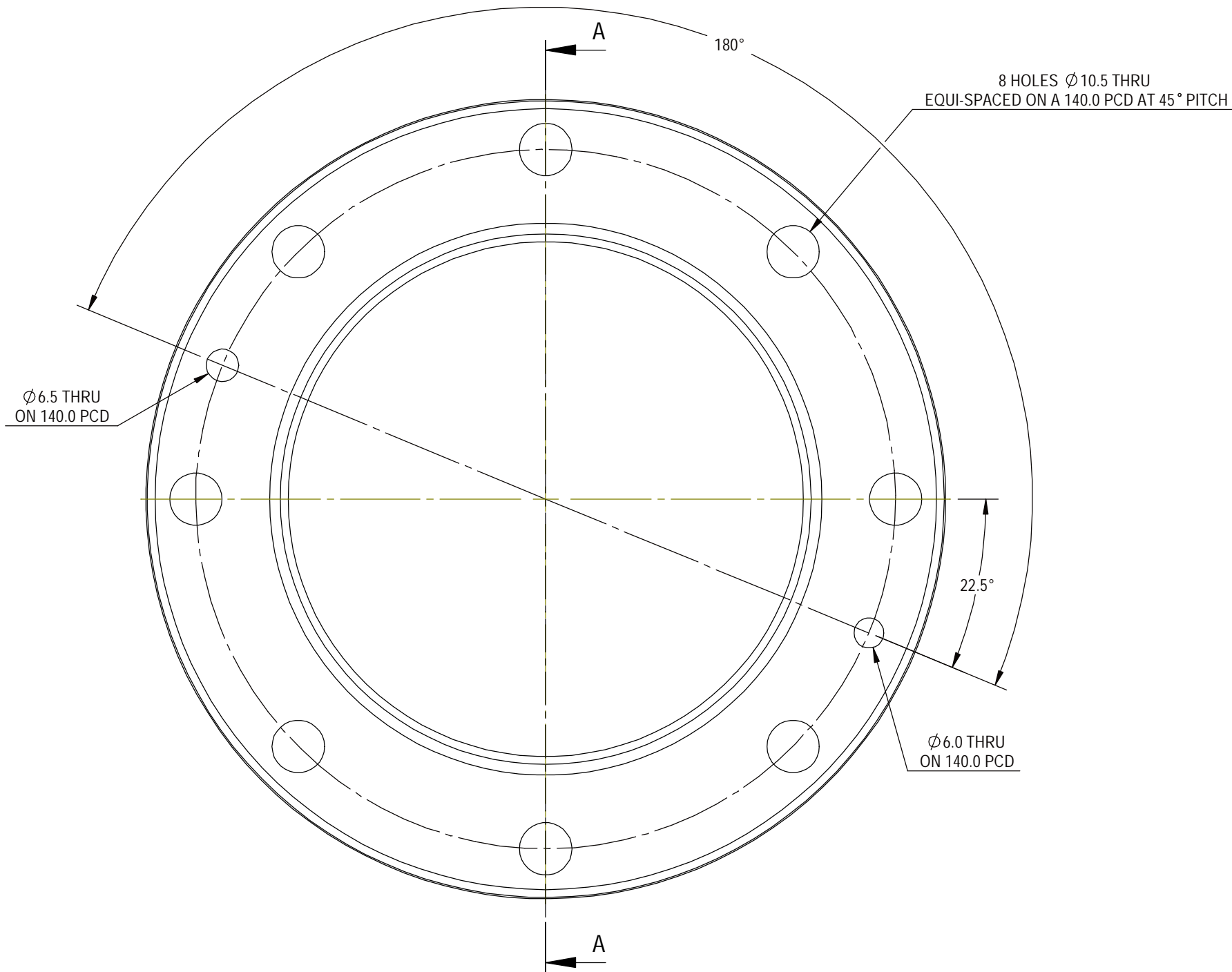

SECTION A-A

DESIGN FILE No.	ECM15605		<b>4-1/2 FLANGE-HARD SOLDER</b>  38.20004
CHECKED	K.J.T.		
WEIGHT			
SHEET No.	SHEET 1 OF 1		
ISSUE	11	DIMENSIONS IN MILLIMETRES	

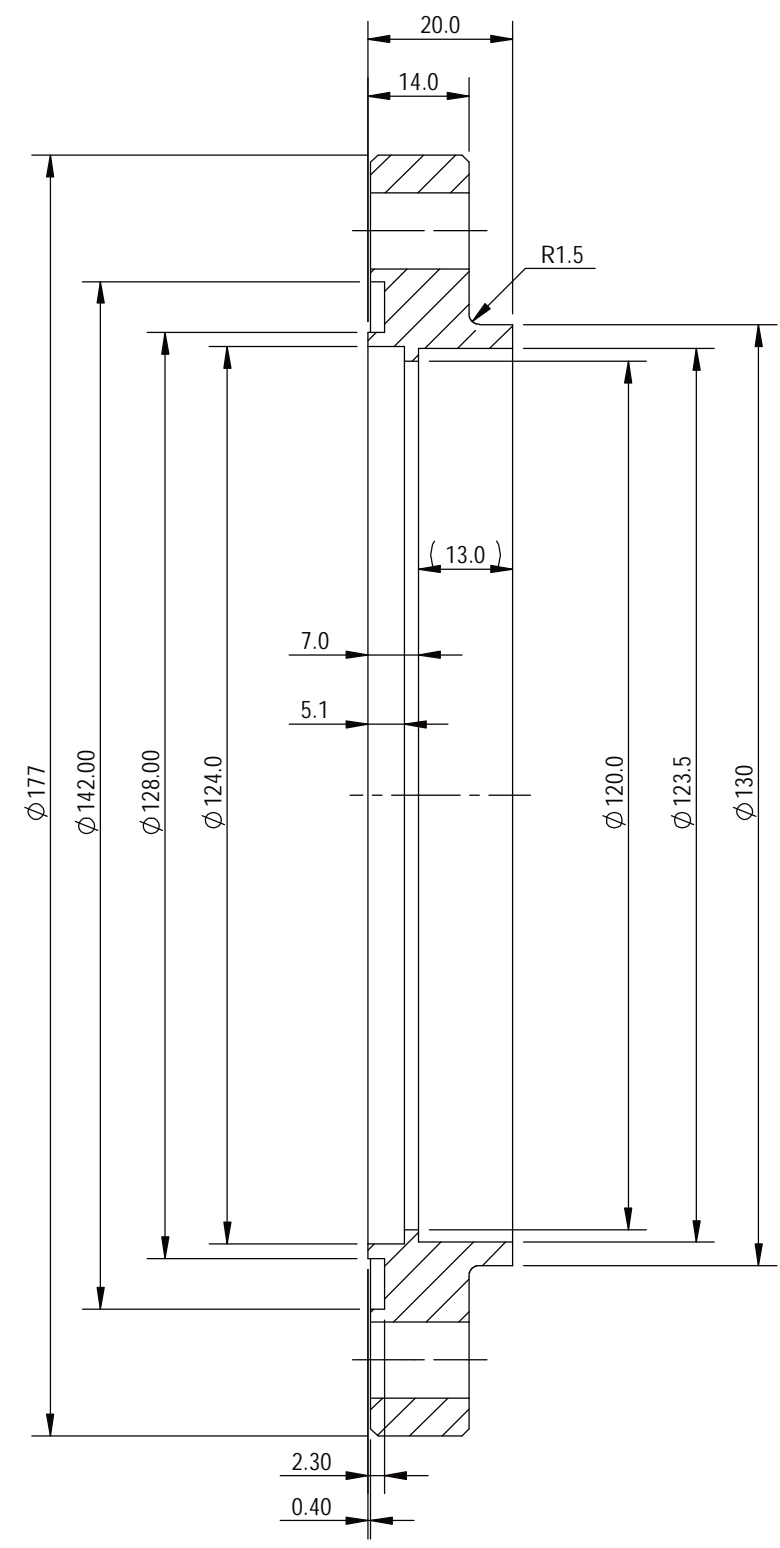
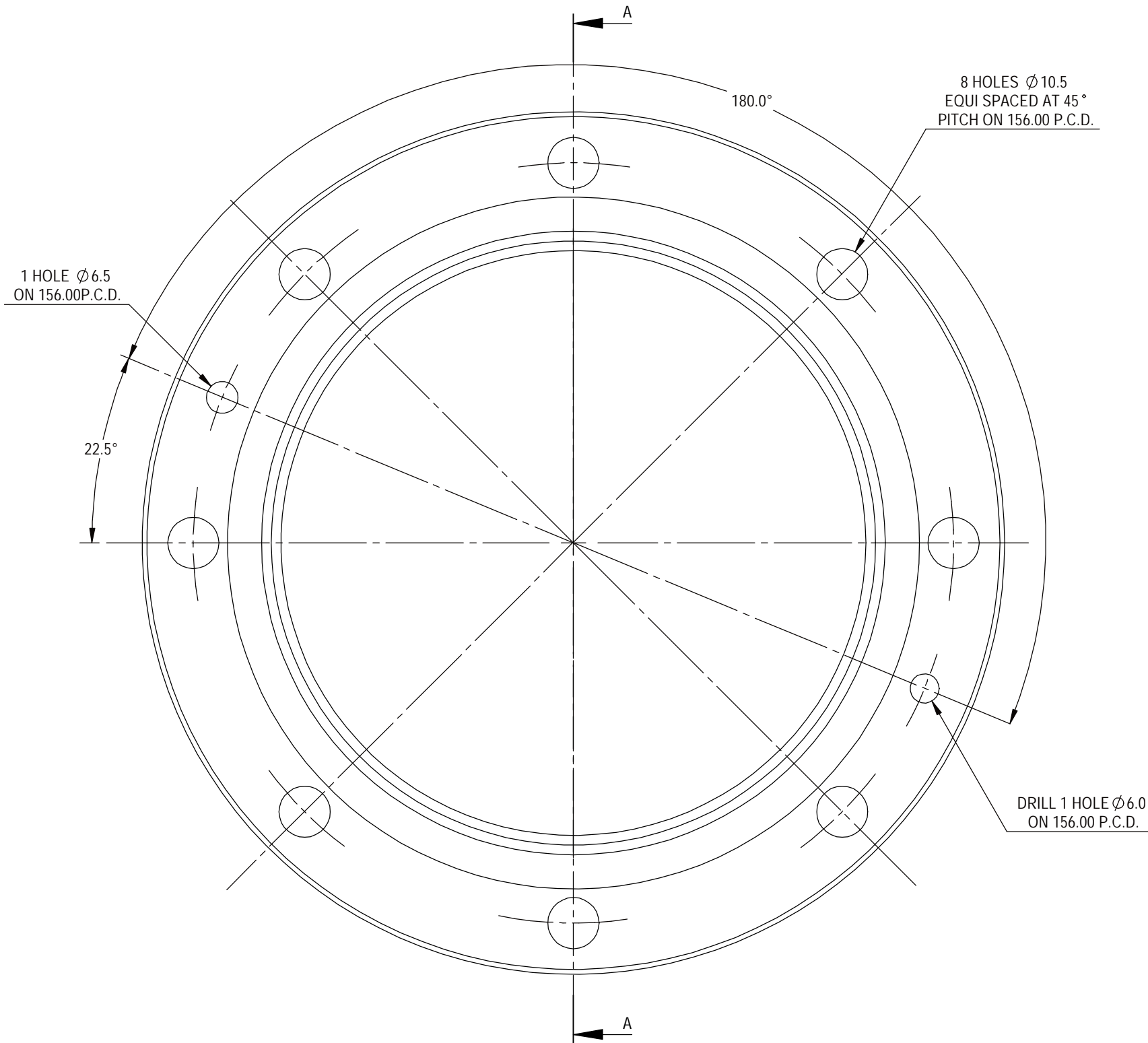

SECTION A-A

DESIGN FILE No.	ECM14648
CHECKED	K.J.T.
WEIGHT	
SHEET No.	SHEET 1 OF 1
ISSUE	02

**RFS** RADIO  
FREQUENCY  
SYSTEMS

DIMENSIONS IN MILLIMETRES

4 7/8" FLANGE - HARD SOLDER

51.20018

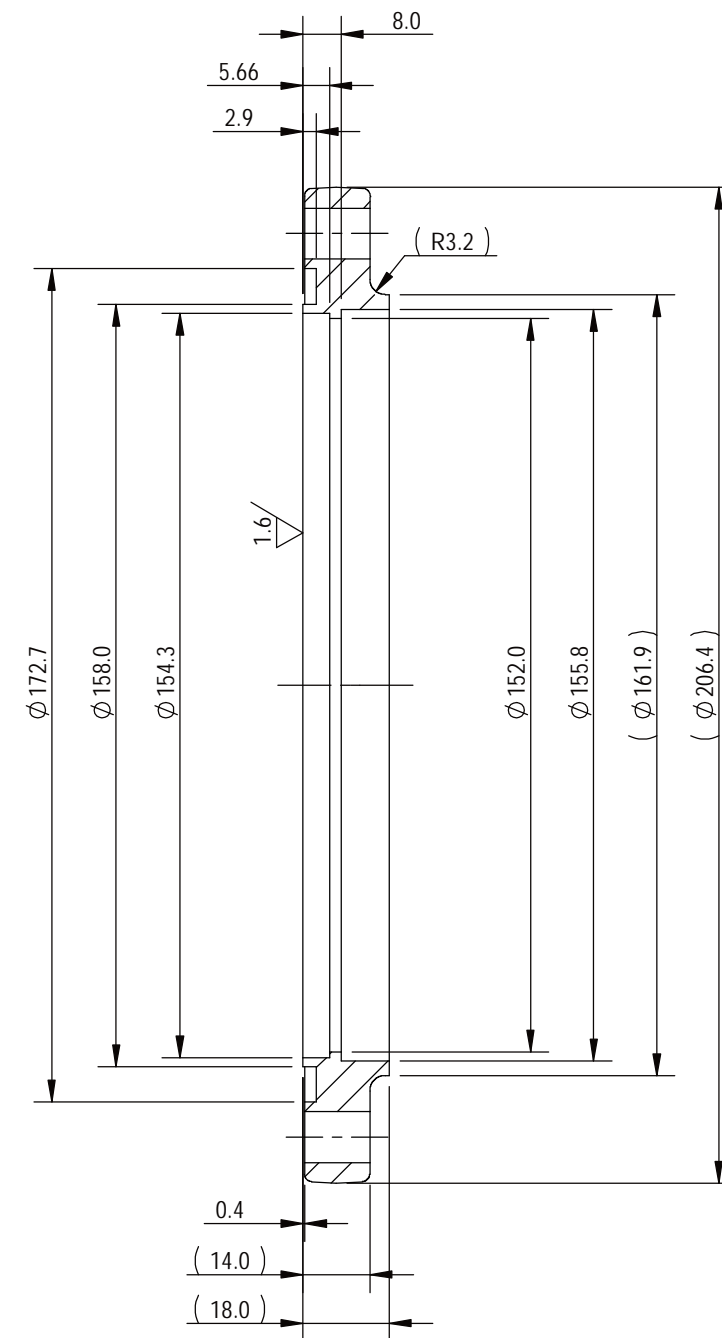
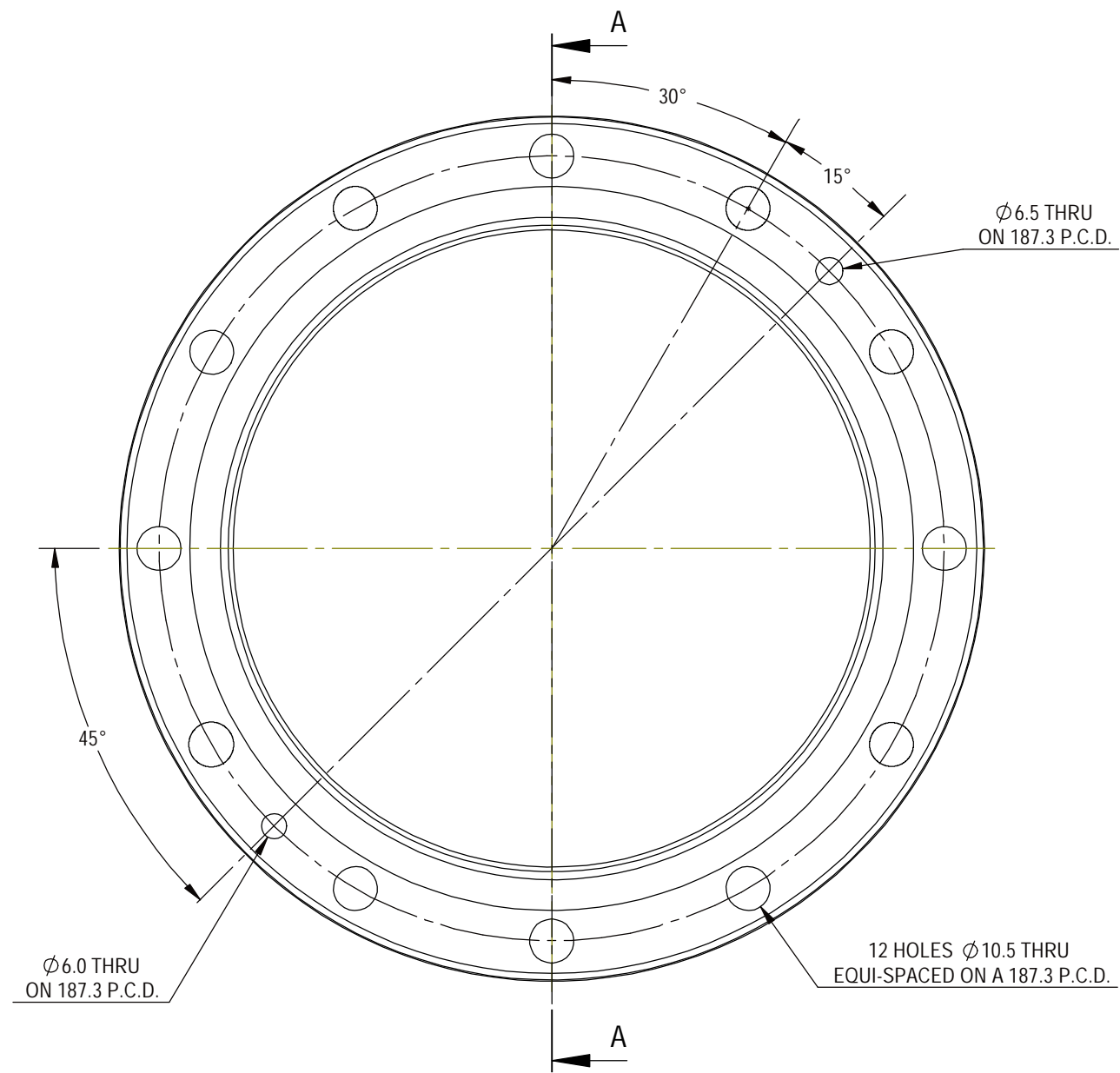

SECTION A-A

DESIGN FILE No.	ECM15457		6-1/8 FLANGE-HARD SOLDER
CHECKED	K.J.T.		
WEIGHT			
SHEET No.	SHEET 1 OF 1		
ISSUE	08	DIMENSIONS IN MILLIMETRES	39.20014

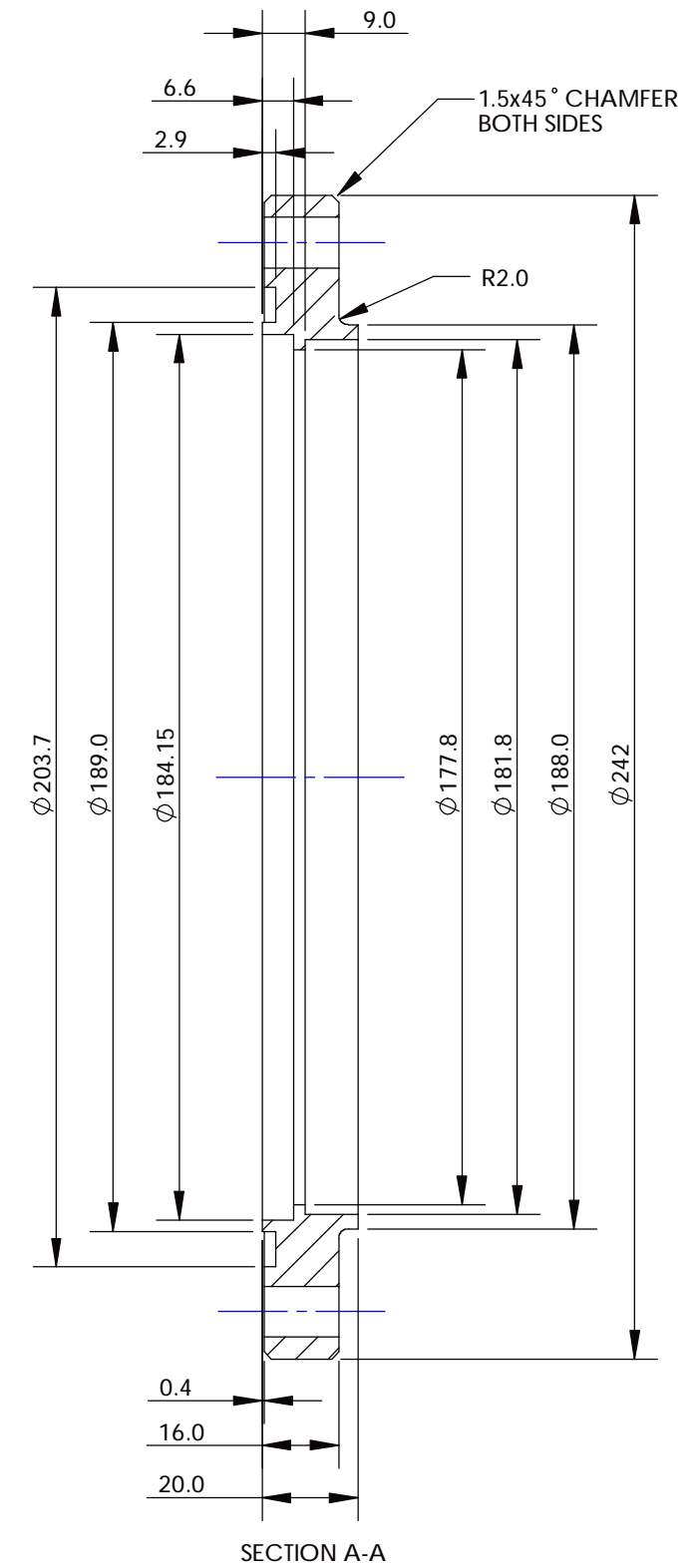
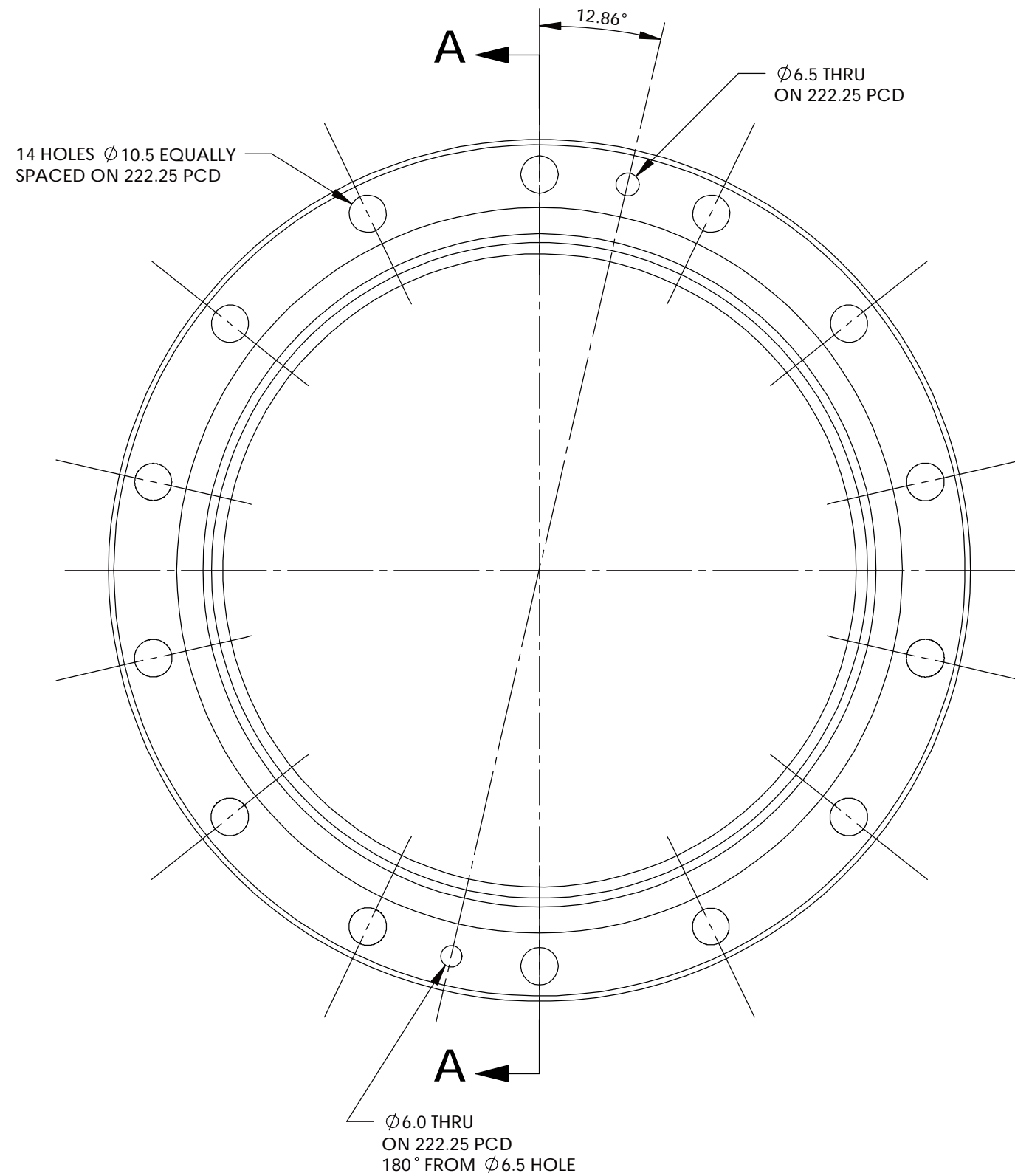

DESIGN FILE No.	DF020.061.00
CHECKED	K.J.T.
WEIGHT	
SHEET No.	SHEET 1 OF 1
ISSUE	01



DIMENSIONS IN MILLIMETRES

FLANGE HARD SOLDER 71

54.20005